

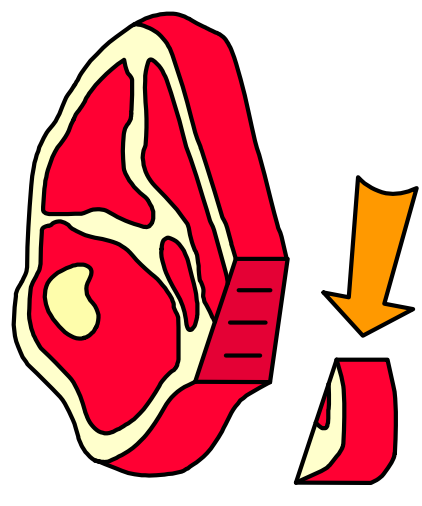

bakken

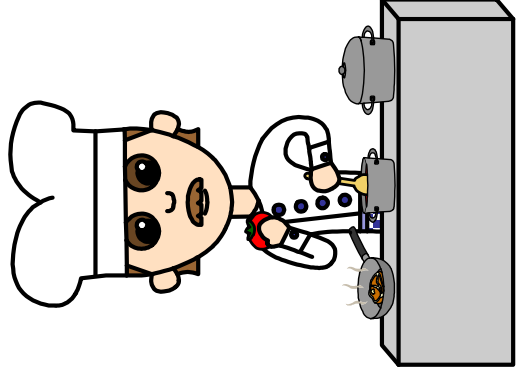

het stukje



koken

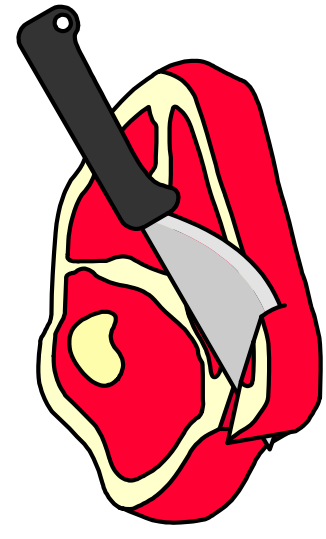

snijden

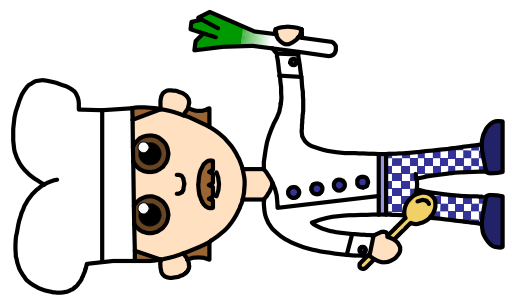

de kok

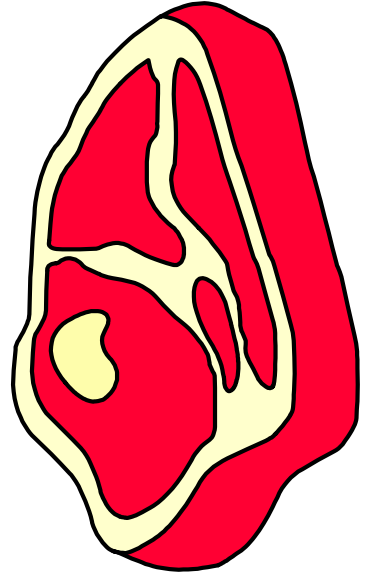

het vlees

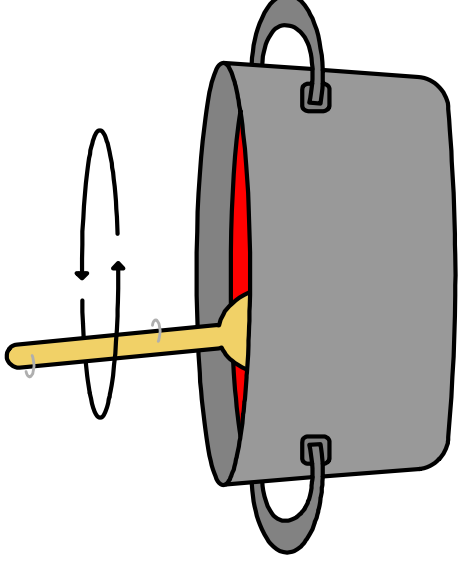

roeren

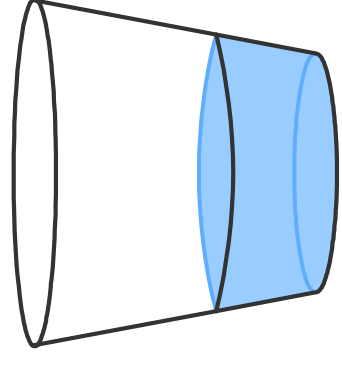

het glas

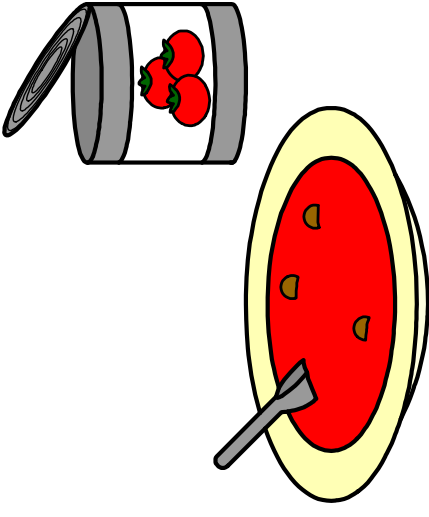

de soep

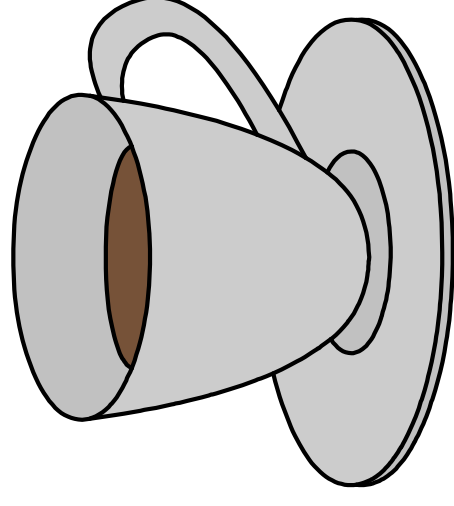

het kopje

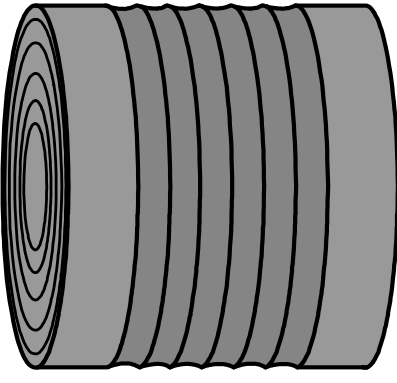

het blik

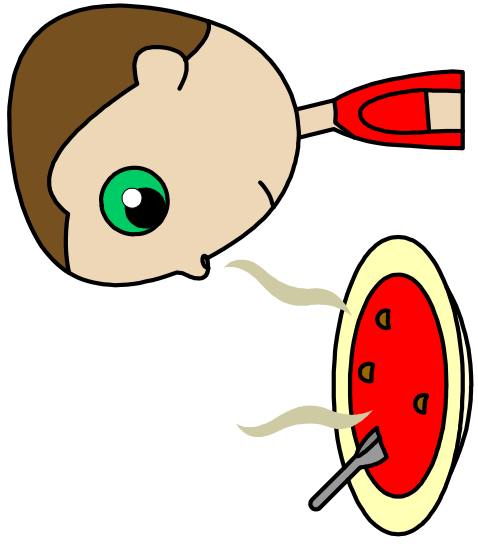

ruiken



het mes

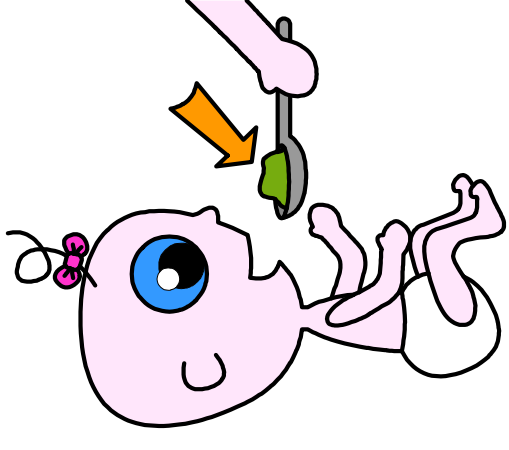

het hapje

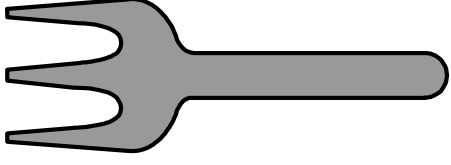

de vork

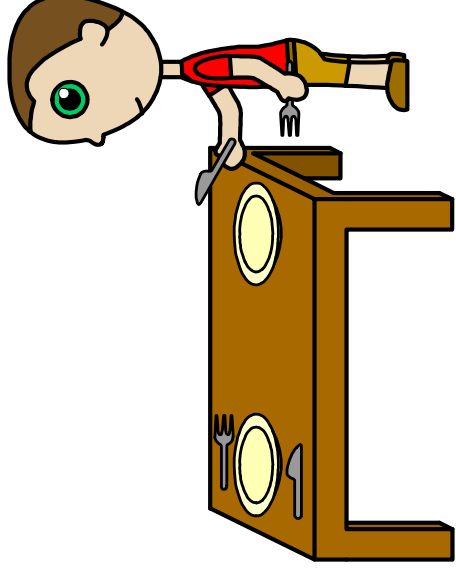

tafeldekken

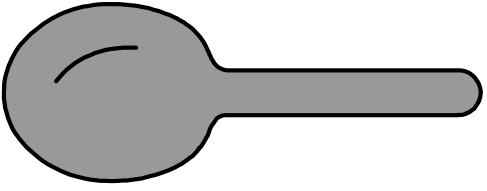

de lepel

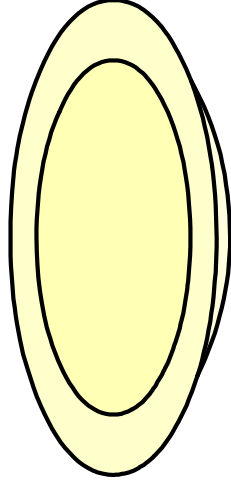

het bord

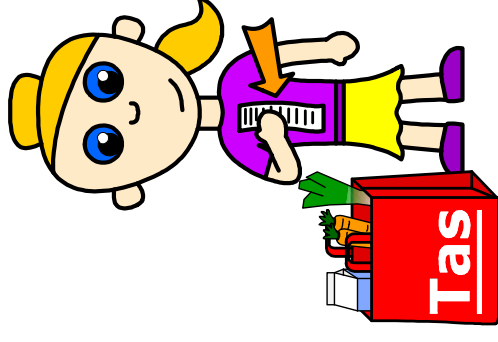

de kassabon

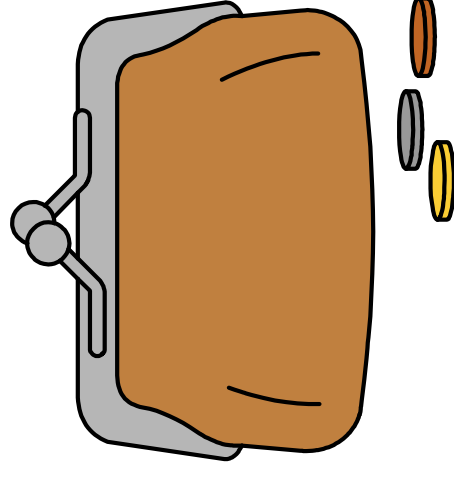

de portemonnee

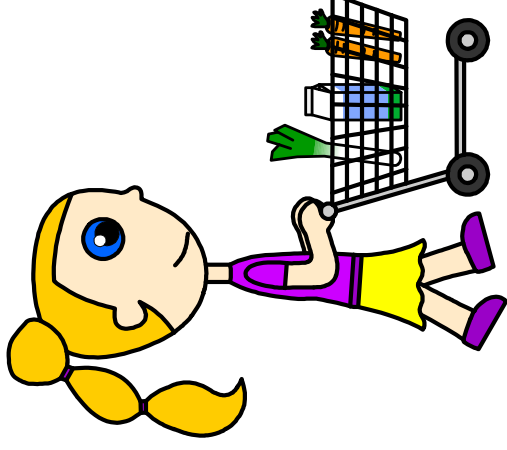

boodschappen doen

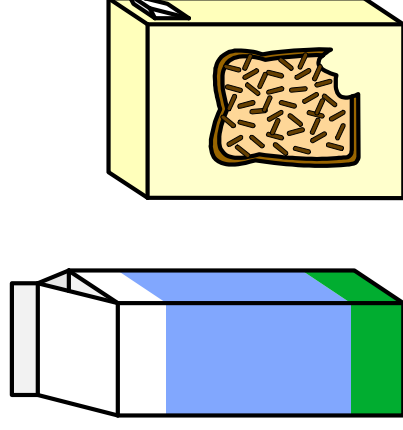

het pak

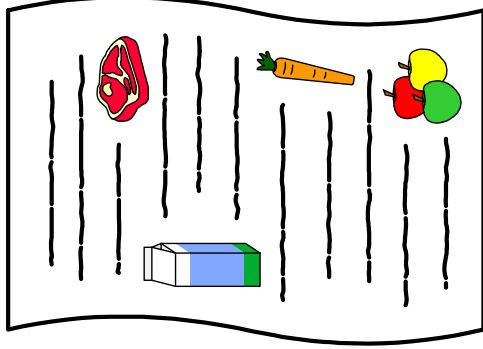

het boodschappenlijstje

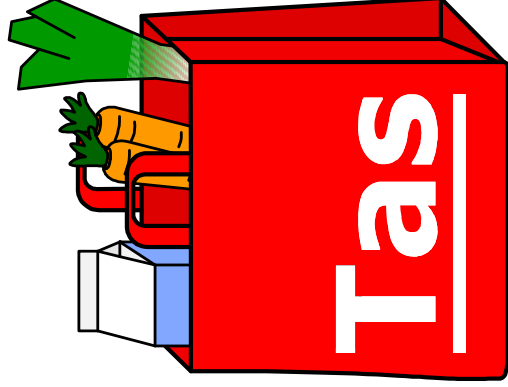

de boodschappentas

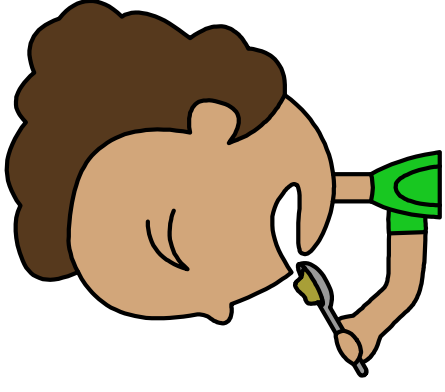

vies (smaken)

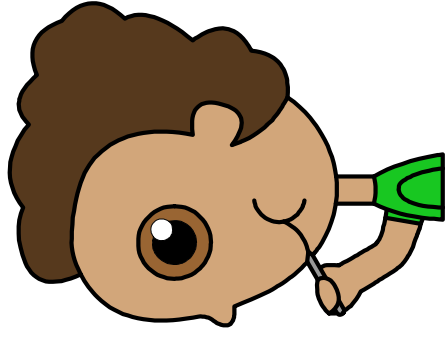

lekker (smaken)

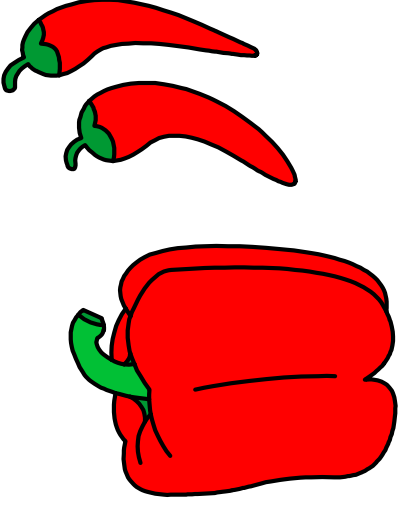

scherp

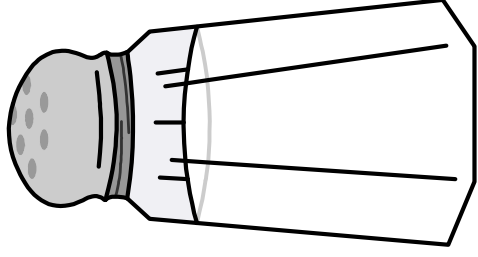

zout

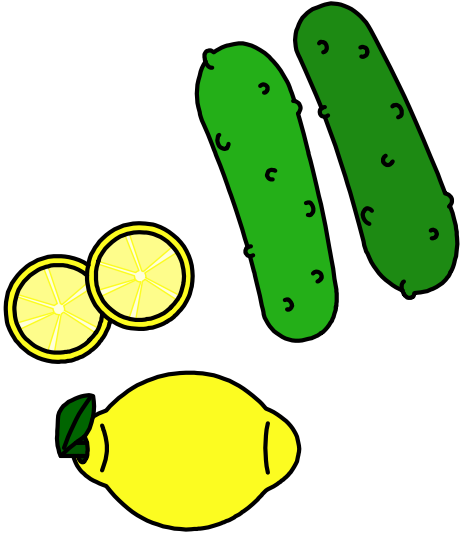

zuur

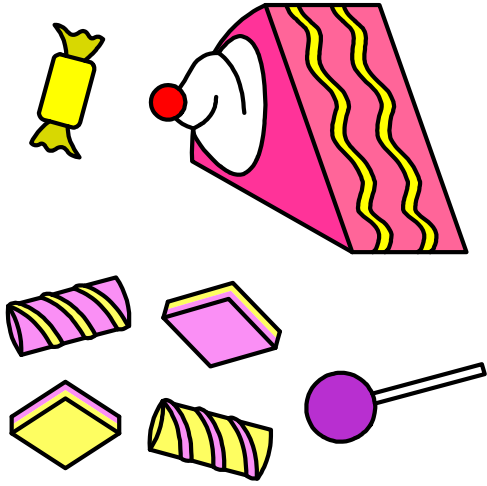

zoet

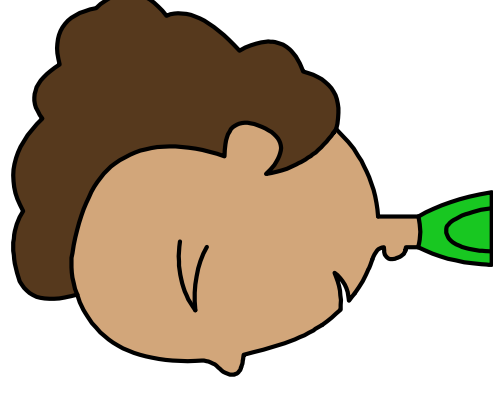

de slok/slikken

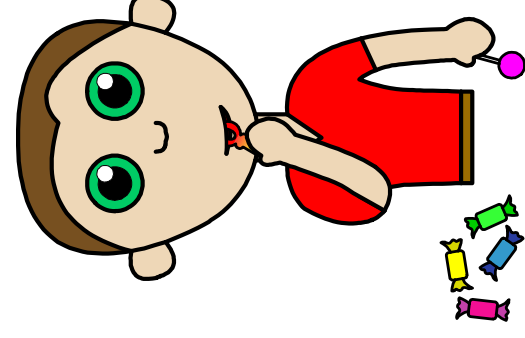

snoepen

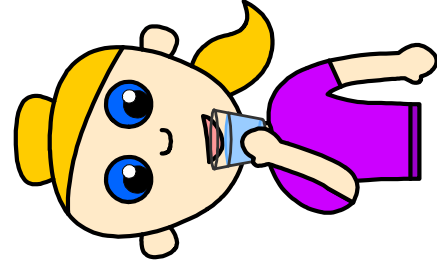

drinken

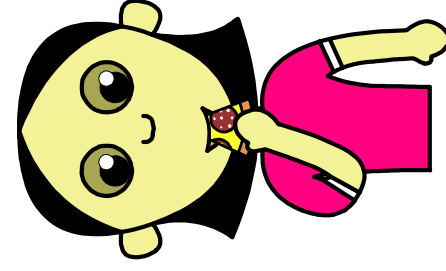

eten

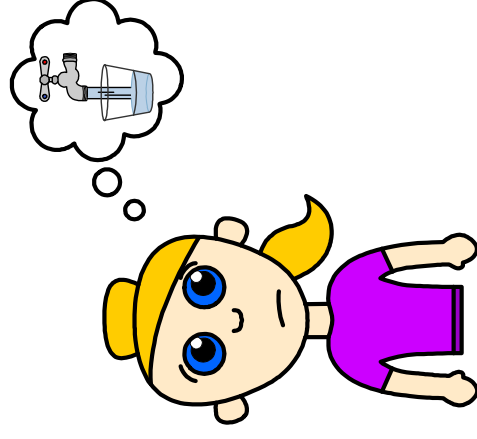

dorst hebben

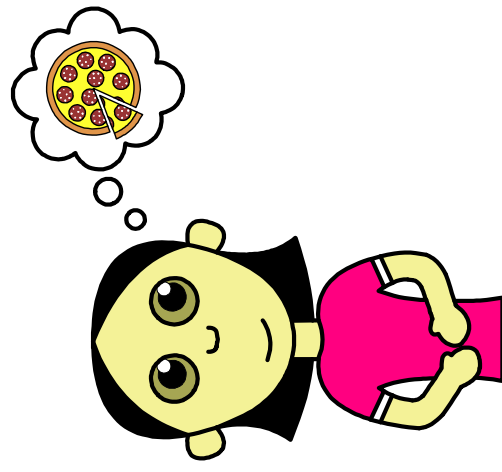

honger hebben

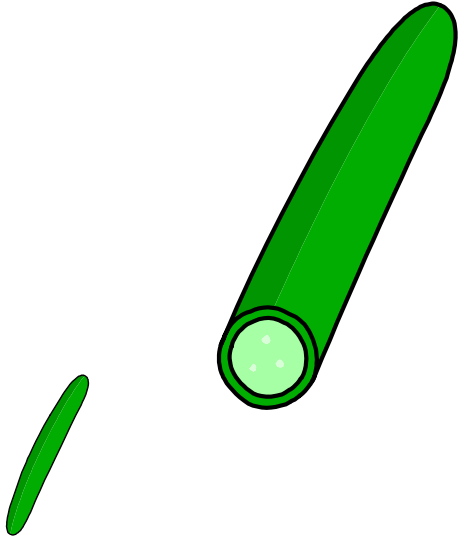

half

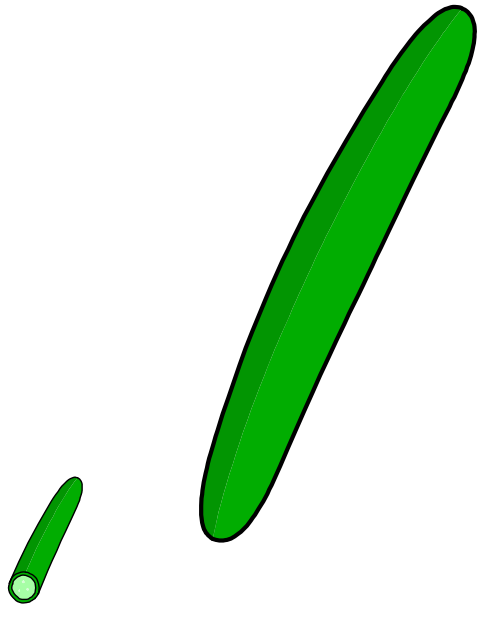

heel

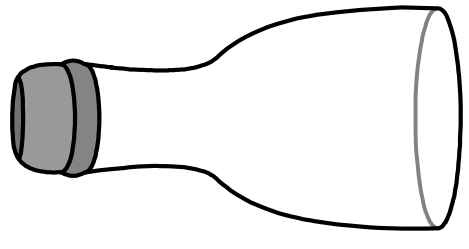
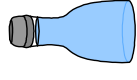

leeg

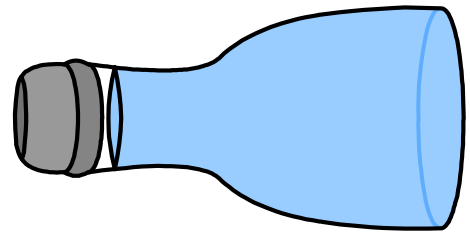
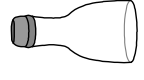

vol

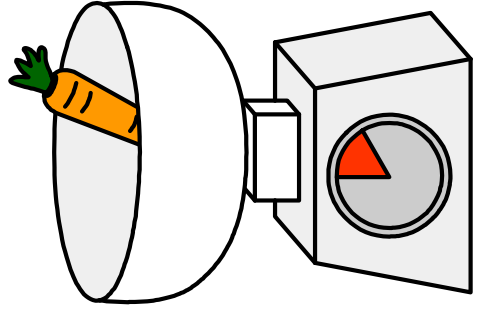

licht (gewicht)

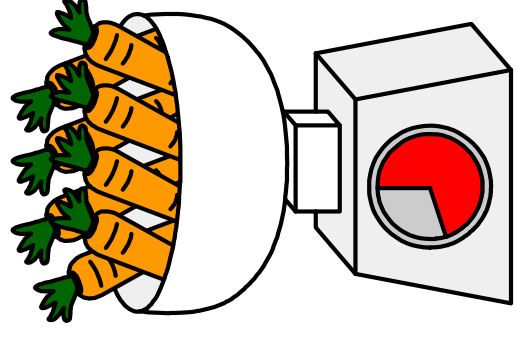

zwaar (gewicht)

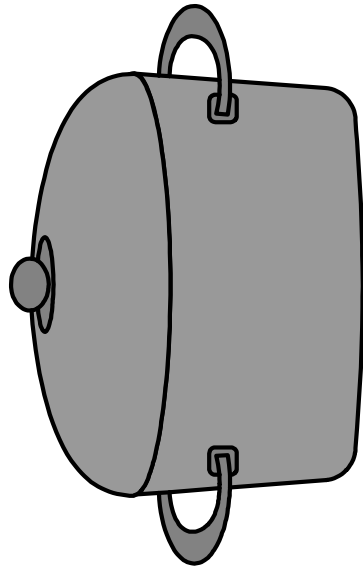

de pan

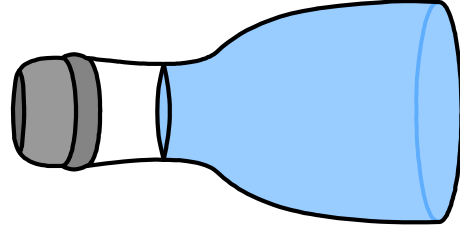

de fles

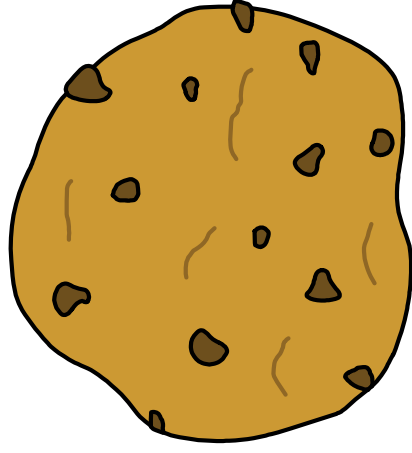

het koekje

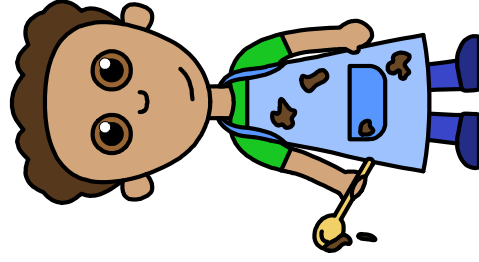

knoeien

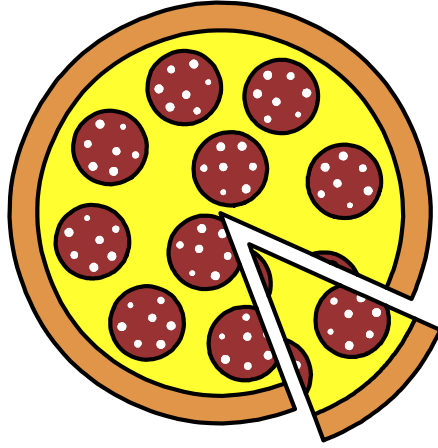

de pizza

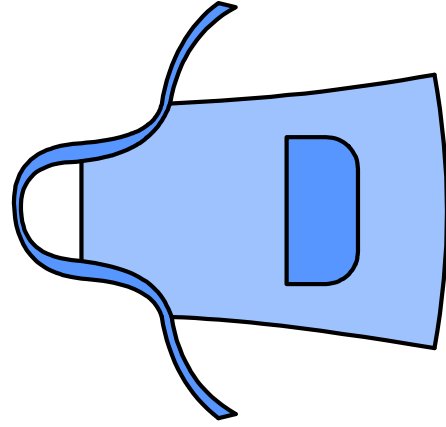

de/het schort

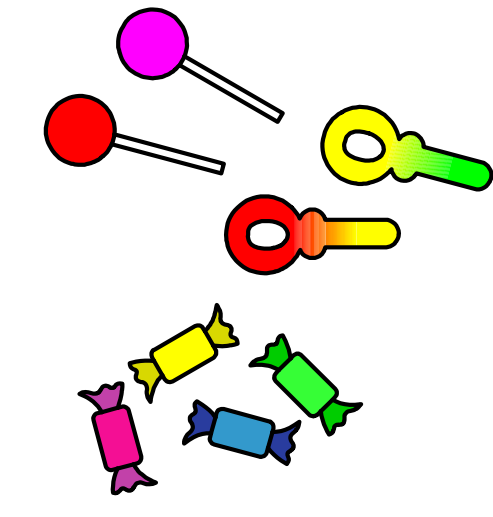

de/het snoep

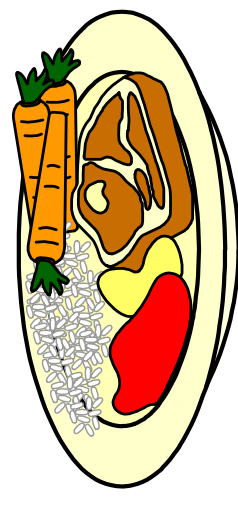

veel

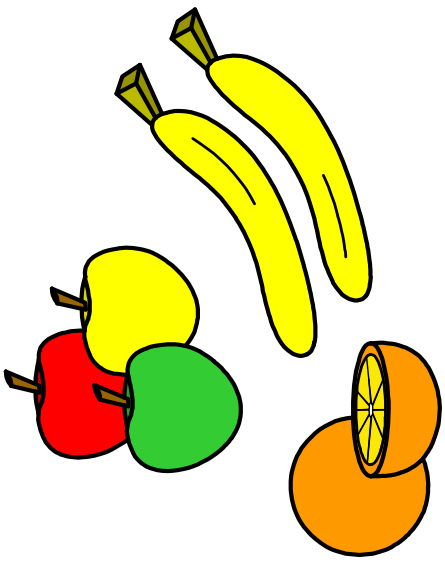

het fruit

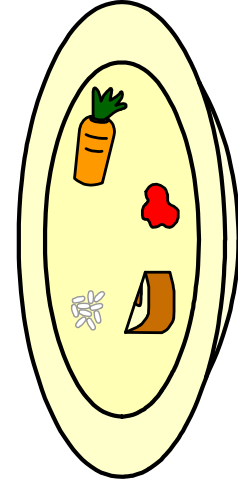

beetje

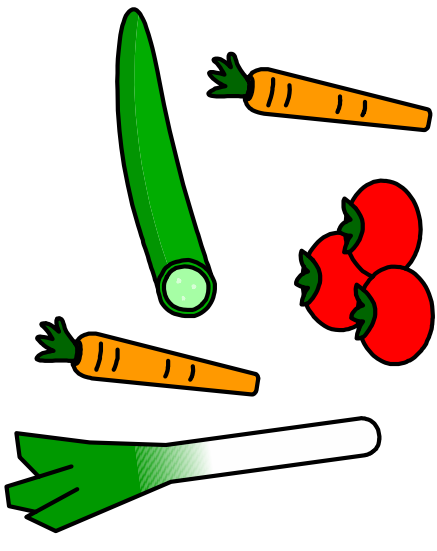

de groente

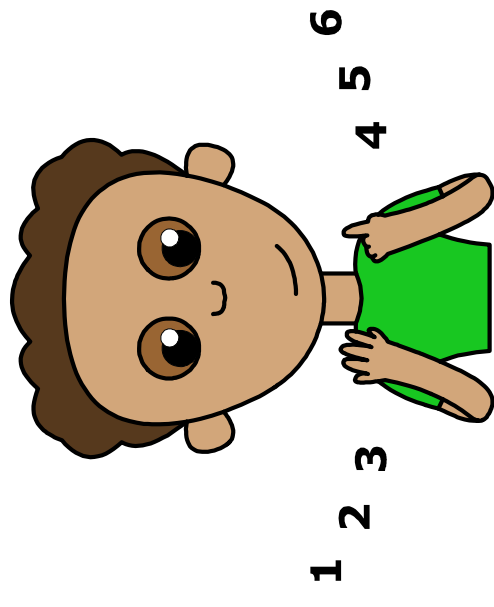

tellen